

**ZT-30**  
**ZeroTEM TRANSMITTER**  
**MANUAL**

**06 September, 2000**

***Zonge International***

3322 East Fort Lowell Road, Tucson, AZ 85716 USA  
Tel:(520)327-5501 Fax:(520)325-1588 Email:[zonge@zonge.com](mailto:zonge@zonge.com)

# READ THIS FIRST

## WARNING:

Before operating your transmitter, we recommend you read or at least skim the entire manual.

Also, be sure to connect the Logic Battery as it is disconnected for shipping. To do so, remove the Front Panel. The connector to the batteries is at the left end of the case. It is the white Molex. Always disconnect the batteries for shipping or when long term storage is required. There is a 100 microamp current drain whenever the batteries are connected. Once you have connected the batteries, charge for six (6) hours or until the Green Light comes on.

## CRITICAL WARNING:

- **MAXIMUM INPUT VOLTAGE: 400 Volts D.C. DO NOT REVERSE POLARITY. YOU WILL BLOW THE FUSE!**
- **DO NOT CONNECT THE LOGIC POWER TO THE INPUT POWER. THIS MAY SEVERLY DAMAGE THE UNIT.**
- WATCH INPUT POLARITY AT THE BATTERY CONNECTORS. USE A HEAVY GAUGE JUMPER BETWEEN BATTERIES (at least 8 awg).
- THERE IS A FIVE SECOND DELAY AFTER POWER IS TURNED ON FOR CIRCUITS TO STABILIZE, SEE CONTROL INFORMATION.
- YOU HAVE TWO SECONDS AFTER PUSHING THE RESET TO PUSH TRANSMIT, OTHERWISE YOU MUST PUSH RESET AGAIN.
- **DO NOT OPERATE INTO A SHORT CIRCUIT, (less than 0.5 OHMS).**
- THERE IS AN INTERNAL RESISTANCE ON THE ORDER OF 1.0 OHM.

## SECTION 1 DESCRIPTION OF THE ZT-30 TRANSMITTER

### 1.1 INTRODUCTION

The ZT-30 ZeroTEM Transmitter is a battery powered transmitter designed to transmit into a loop between 50 and 1000 meters with a resistance of 1 ohm or greater. It will transmit a time-domain signal between DC and 32 hertz. It is capable of frequency domain operation from DC to 512 hertz.

The maximum current is 30 amps.

The input voltage range is from 14 to 400 volts DC. The transmitter is designed for use in hostile environments and will work over a temperature range of -25 C to 65 C.

It uses individual piezo touch-switches for each function. These are solid state switches, environmentally sealed.

The ZT-30 is a modular device with replaceable P.C. boards and an IGBT (Insulated Gate Bipolar Transistor) output.

### 1.2 ELECTRICAL & MECHANICAL SPECIFICATIONS

<b>Description:</b>	Unregulated variable voltage input transmitter with IGBT output bridge.
<b>Frequency Range:</b>	DC-32 Hz. Time Domain DC-512 Hz. Frequency Domain
<b>Survey Capabilities:</b>	TEM Loop driver, Resistivity, IP Transmitter
<b>Power:</b>	14 to 400 V DC Battery Powered using ZPB-600.
<b>Maximum Current:</b>	30 amps TEM, switchable to 7.5-amp range using Resistivity setting. See Appendix A
<b>Temperature Range:</b>	-25 C to +65 C.
<b>Humidity Range:</b>	0 to 100%
<b>Switching Range:</b>	250 nanoseconds into a resistive load.
<b>Damping Circuit:</b>	SCR switched damping resistor, switch selectable between 60 ohms, 120.ohms, and 240 ohms.
<b>Size:</b>	43 X 25 X 17 cm (17 X 10 X 6.5 in.)
<b>Weight:</b>	10 kg (25 lb.)
<b>Enclosure:</b>	Heavy-duty, environmentally sealed ABS plastic case.

**Liquid Crystal Display:** Input and Logic Voltage, Output Current, Decay Time, and Internal Temperature.

**LED Indications:** Power ON, Transmit ON, Polarity shows Plus or Minus, Meter Select shows over current, over voltage, and over temperature.

**Sealed Controls/Keys:** Power off, Power on, Meter Select, Reset, and Transmit.

### 1.3 FRONT PANEL

The front panel contains the displays, control keys, and connectors. Operator control of the ZT-30 is through the front panel.

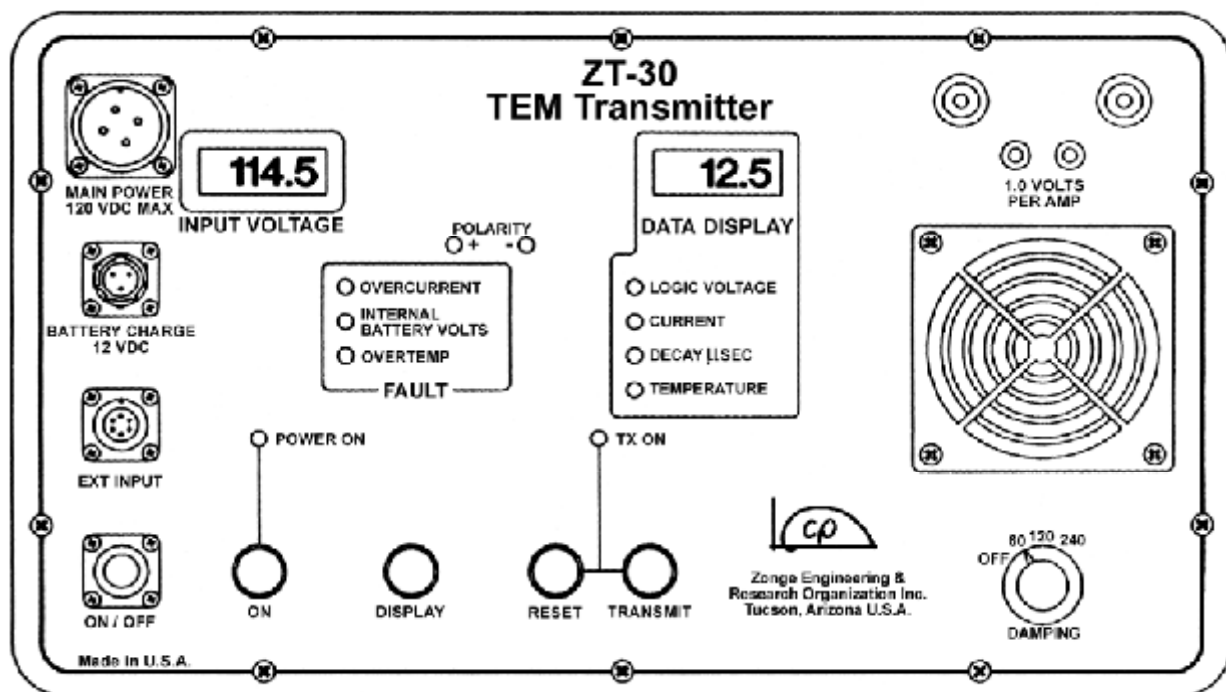

Figure 1: Front Panel

- 1) **Liquid Crystal Displays:** There are two displays for transmitter status. The left most display will indicate the battery input voltage at all times. The right display indicates different parameters as selected by the meter select switch. This meter can display logic battery voltage, output current, decay time in microseconds, and regulator heatsink temperature.
- 2) **Transmitter ON Key:** After turning on Logic Power with the Transmitter ON / OFF Button in side MIL-connector, with LED on, press Transmitter ON Key. The transmitter generates an internal 5 seconds delay each time it is turned on to allow the power supply to stabilize. The control circuits remain reset until this times out. There is power applied to the switch circuits whenever the logic batteries are connected.

- 3) **Transmitter ON / OFF Button:** This key controls power to the transmitter. After the transmitter is connected to the battery, pressing the **ON/OFF** button will energize the internal power supply. Pressing the **ON/OFF** button at any time will reset the transmitter and turn off power to the internal supplies. During low battery mode the Tx will turn off. Cycle the **ON/OFF** button to restart.
- 4) **RESET and TRANSMIT:** These keys control the output of the transmitter. **RESET** must be pushed before **TRANSMIT**. You have two seconds after **RESET** to press **TRANSMIT**. This is to avoid an unwanted transmission if the key is accidentally pressed. Any fault condition will generate a reset condition.
- 5) **DISPLAY:** This key controls the function selection from the options in the DATA DISPLAY section. The indicator light will cycle through the following functions until an option is selected.
  - A) **LOGIC VOLTS:** This is the voltage of the internal logic batteries.
  - B) **CURRENT:** This is the actual output measured across the output current sense resistor. It is sampled just before turnoff and sent to a true RMS converter. The output is buffered and sent to the DATA DISPLAY. It is switchable between 0 - 199.9 amps and 0 - 19.99 amps full scale.
  - C) **DECAY  $\mu$ SEC:** This displays the time it takes for the current to reach zero after the output is turned off. It displays the time in microseconds.
  - D) **TEMPERATURE:** This displays the temperature in degrees centigrade at the output heat sink. The maximum temperature for operation is 65 C. A reset will be generated above 65 C.
- 6) **FAULT:** This section includes the following indicators:
  - A) **POLARITY:** These lamps represent the polarity of the output to the loop. When they are flashing, it shows that the output is switching.
  - B) **OVERCURRENT:** This lamp lights when the output current has exceeded thirty-three amps. It also indicates that the transmitter has turned off. Push **RESET** to clear the indicator and either increase the loop resistance or decrease the battery input voltage.
  - C) **INTERNAL BATTERY VOLTS:** This lamp indicates an under or overvoltage condition which is set for less than eleven volts or greater than 15 volts. It will also reset the transmitter and must be cleared by pushing **RESET** before operation can resume. Check for proper battery connection or voltage.
  - D) **OVERTEMP:** This lamp come on when the temperature of the output heat sink exceeds 65 C before operation can be resumed. If **OVERTEMP** occurs, use a lower current by adding resistance to the loop or lowering the input voltage by removing batteries from the string.
- 7) **MAIN POWER:** This connector is for the DC input to the transmitter. The transmitter accepts voltages from 14 to 400 volts DC.
- 8) **BATTERY CHARGE:** Internal Battery Charge connector is the charge port for the internal twelve-volt battery that powers the logic.

- 9) **EXT INPUT:** Signal input to externally control the ZT-30. Period and duty cycle (i.e. polarity and transmitter on/off) signals may be provided from an XMT-32 or GDP-32
- 10) **0.1 VOLTS / AMP or 1.0 VOLTS / AMP:** These jacks provide an output from the current sense resistor. They measure across the 0.05 ohm current sense resistor and provide an accurate current signal. Switchable between 0.1 V and 1.00 V / amp. 1.00 V / amp in Resistivity Mode. See Setup Board 248.
- 11) **OUTPUT JACKS:** Rated at 35 amps and provide connection to the loop. Good wiring must be used to avoid any voltage drop across the connections. If they get hot, reduce the current.
- 12) **FAN:** The fan is necessary when extra cooling is needed for high power operation or high temperature operation. In certain conditions, such as Resistivity Mode, it is acceptable to unplug the fan to save power from the batteries. Be sure to check heat sink temperature when the fan is unplugged. A temperature control unit will be available which will turn the fan on and off.
- 13) **DAMPING:** Selection of loop damping resistors: **OFF** (open), **60**, **120**, or **240** ohms.

## **SECTION 2 OPERATING SUMMARY**

This is a basic startup procedure to enable the operator to follow the basic functions of the transmitter without having to be fully conversant in its operation.

### **2.1 BOARD 248 SETUP**

There are two settings for Board 248 (figure 2). TEM operation is for high current, and RESISTIVITY operation is for high voltage. Refer to the diagram on top of the AD-210 isoamp for jumper settings.

- 1) **TEM** jumpers:
  - Current meter: one decimal place, for currents above 20.0 amps.
  - Isoamp gain: 0.1 volts per amp at the current sense jacks.
  - Maximum current: 30.0 amps.
- 2) **RESISTIVITY** jumpers:
  - Current meter: two decimal places, for current to 0.01 amps.
  - Isoamp gain: 1.00 volts per amp at the current sense jacks.
  - Maximum current: 7.5 amps.

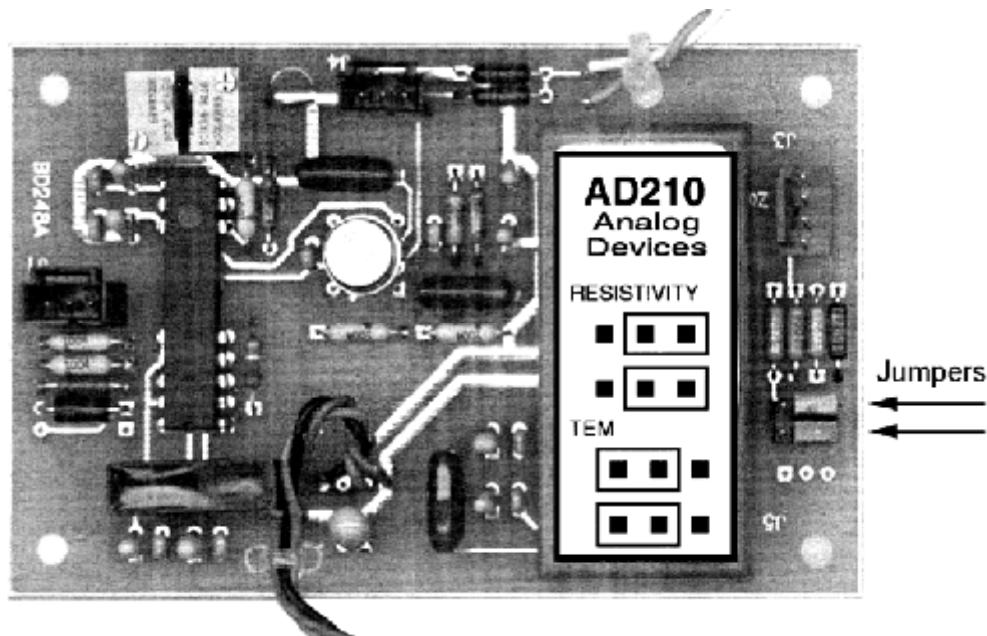

Figure 2 Setup jumpers on Board 248

## 2.2 TRANSMITTER START UP

To power up the transmitter, first connect the power cable to the transmitter and then connect to a 24 volt battery of at least 10 amp-hour capacity.

NOTE: A smaller capacity battery can be used for testing.

Press the **ON** switch. The Control LED lamps should light in the following sequence.

The **POWER ON** lamp, and one of the **DATA DISPLAY** lamps will come on. If any of the fault lamps are on, press **RESET**. This will power up the transmitter control.

The input voltage should be displayed in the left-hand display. At this time the circuits will be activated and a delay of five seconds is generated to allow for circuits to stabilize. If all fault lamps are extinguished, the transmitter is ready to transmit.

Use a digital voltmeter to check the loop for continuity and a low loop resistance. Ensure that the controller is connected to **EXT INPUT** and is turned on. Plug the loop into the output jacks using the supplied connectors to minimize contact resistance.

Press **DISPLAY** to set the meter select to **CURRENT**, then press **RESET**. Within two seconds press **TRANSMIT**: the output bridge should turn on and the output current should display. Depending on the output current needed, adjust the output voltage by removing or adding batteries to the string.

### WARNING

Watch the heat sink temperature. It is permissible to operate up to 65 C.

At 20 amps the ZT-30 will operate continuously for many hours, depending upon the ambient temperature. At 30 amps the temperature will rise rapidly, resulting in an over-temperature condition within an hour, again depending upon the ambient temperature.

## SECTION 3 SERVICE

The following section covers maintenance of the ZT-30, common problems and repair of the transmitter.

### 3.1 FAULT CONDITIONS

#### What lights are on?

- 1) The Internal Battery Volts lamp will not reset: Is it too low or too high (<14 volts or >15.5 volts)? Is there a good connection to the battery pack?
- 2) The Over-temp Lamp will not reset. Check the heatsink temperature. Is it >65 C? If so, let cool until temperature is below 50 C. Check that the fan is operating and the air filter is not clogged.
- 3) Over-current lamp will not reset. Check IGBT's. This condition signifies that there exists a bad IGBT device. Go through the checkout procedure in Section 3.2.
- 4) Over-current lamp will reset but comes on in one polarity: This usually indicates a bad gate, but can also indicate a bad diode, RF160A on the drive board. If you replace an IGBT but the same problem occurs, check the diodes, (D3, D7, D12, and D19). They may be open.
- 5) No Power to output: Check 30 amp fuse on inside front panel (figure 3).
- 6) No logic power: Check that logic batteries are plugged in. Check voltage on batteries. If this is okay, check 2 amp fuse (figure 3).

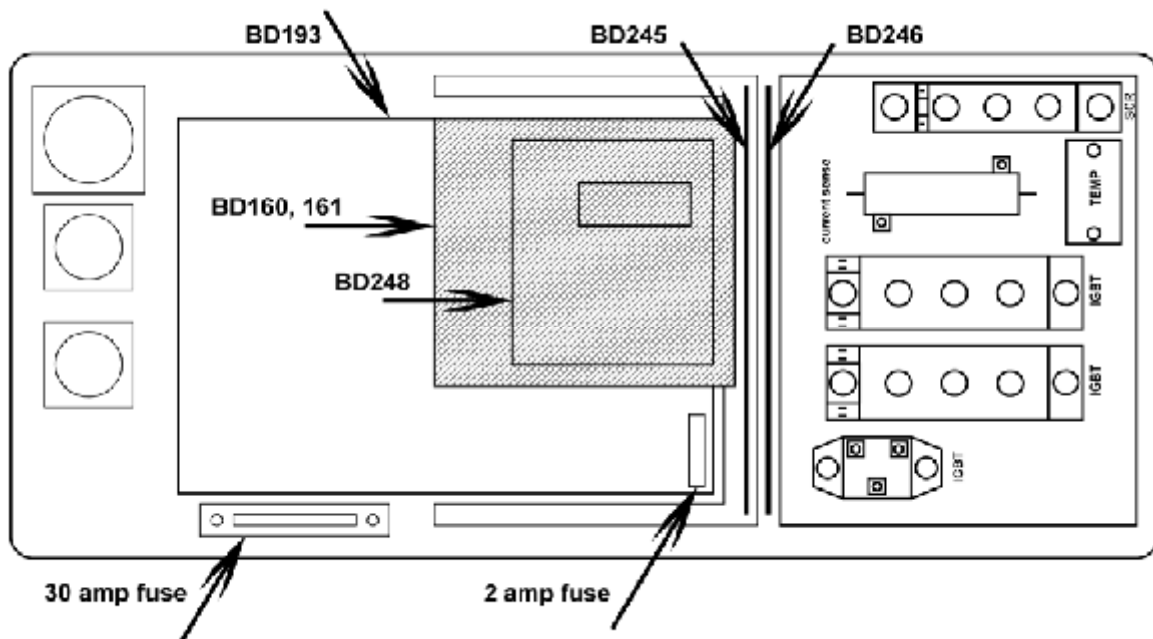

Figure 3: Board locations

### 3.2 IGBT TESTING

The output devices used in the ZT series transmitters are called IGBT's (Insulated Gate Bipolar Transistor). They are faster and can handle higher currents and voltages than the GTO devices they replace. But they do have one disadvantage. Since they have a MOSFET structure to handle the gate drive, there is some sensitivity to static across the gate emitter junction. This means that they need to be handled carefully when installing in the transmitter.

When installing or removing IGBT'S in the transmitters, GGT-3, 10,30, OR ZT-30 the procedure is the same. Do not remove the conductive foam from the gates until the IGBT is connected.

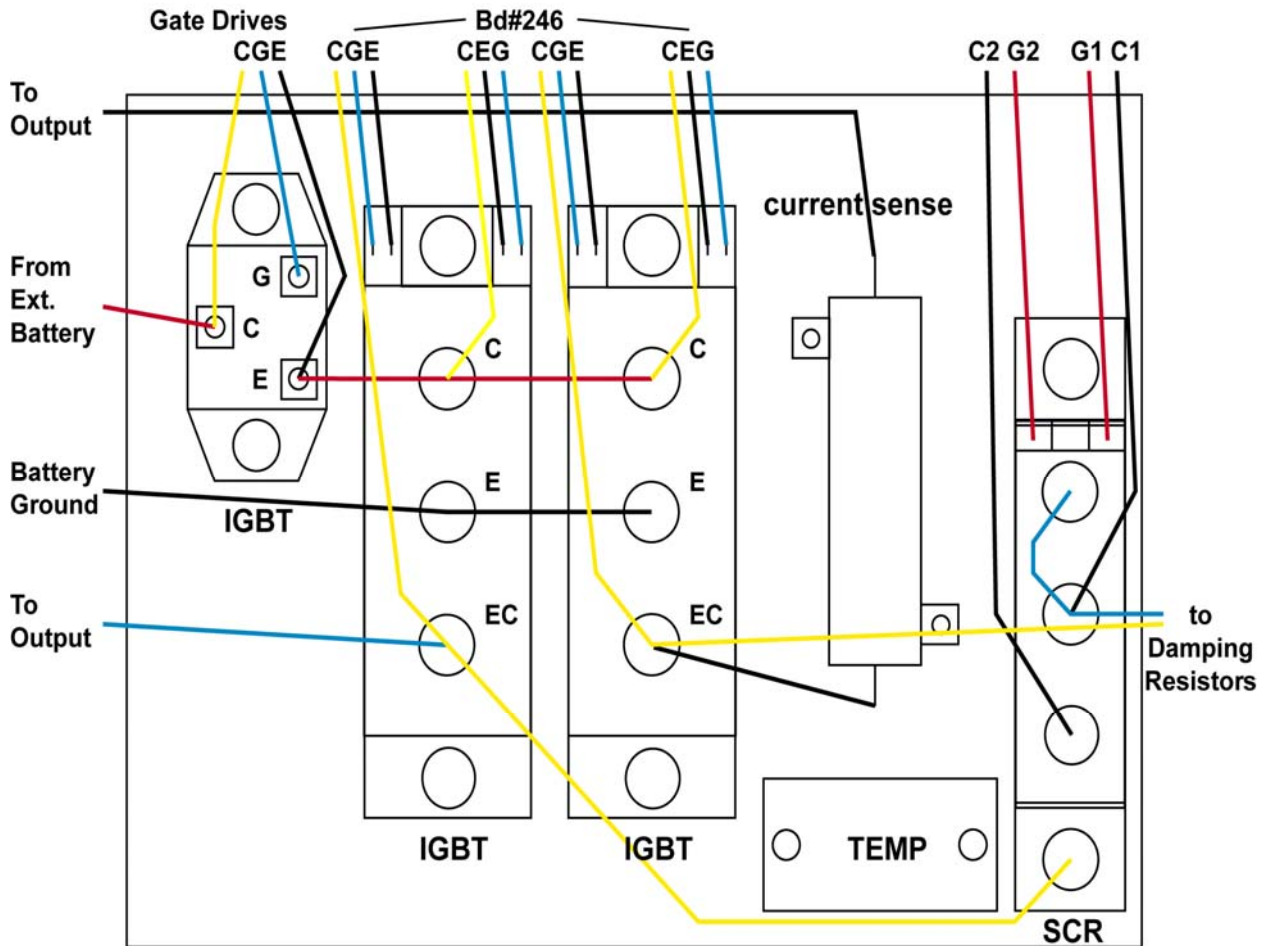

Figure 4: IGBT Wiring

The following is the correct way to check for a bad IGBT.

#### BE CAREFUL WHEN TESTING THE DRIVE TO THE GATES

Note: the transmitter is powered up but not transmitting.

- 1) First it is necessary to determine if the gates are damaged or not. With the power applied to the Tx, set the controller to 0.125 Hz, (If using an oscilloscope, set the controller to 32 Hz) and check with a DVM between the gate and the emitter. The

voltage should swing between +15 volts and –10 volts. If all four gates behave the same way, then the gate operation is okay.

- 2) Next it is necessary to check if the IGBT is operational. First turn off power to the transmitter, Check across each IGBT for collector emitter shorts. With the red lead on the emitter and the black lead on the collector, there should be conduction on the diode scale. If your meter has a diode voltage function, the voltage should be 0.4 volts and infinite on the reverse. If the device is shorted, remove as follows:
  - A) First remove the bad IGBT.
  - B) Install the new IGBT and connect the collector and emitters first. **DO NOT REMOVE** the conductive foam from the gate emitter connections until the IGBT is fully installed in the power circuit.
  - C) After this is done, using a wrist strap connected to the transmitter chassis, remove the conductive foam and connect the gate-emitter leads on both devices.
  - D) Check against the picture in the manual to ensure it is wired correctly (figure 2).

### 3.3 LAB TESTS FOR PROPER OPERATION

After replacing the IGBT, it is necessary to test for proper operation.

- 1) Connect a 24-volt battery to the ZT-30.
- 2) Turn on the ZT-30 and make sure the logic voltage is greater than 12 volts.
- 3) Connect a 4 to 6 ohm resistor or a 50-meter loop to the output.
- 4) Connect an XMT or GDP to the control input, set to 32 Hz for oscilloscope measurements or 0.125 Hz for DVM meter test.
- 5) Press **TRANSMIT**. Does the output current match the current calculated from the input voltage and the load resistance minus any internal losses?
- 6) Does the output waveform look symmetrical on the oscilloscope?
- 7) On a 50 meter, 3 ohm loop, is the decay time approximately 45 microseconds?